

Federal State Unitary Enterprise Production Amalgamation  
"Novosibirsk Instrument-Making Plant"



# Night Sight PN 19K

Service manual  
AL3.812.272 RE



## CONTENTS

Introduction	4
1 Description and operation	5
1.1 Purpose	5
1.2 Specifications	6
1.3 Nomenclature list	11
1.4 Design and operation	12
1.5 Measuring tools, tools and accessories	15
2 Proper use	16
2.1 Operational limitations	16
2.2 Preparation and work procedure	17
Figures	21
3 Maintenance	45
3.1 General instructions	45
3.2 Safety measures	46
4 Possible failures and methods of their elimination	46
5 Storage	49
6 Acceptance certificate	50

## Introduction

The service manual is intended for studying the design and operating rules of the night sight PN 19K.

The service manual contains description of the purpose, specifications, information about the mechanism and operation of the night sight PN 19K, necessary for proper operation and full utilization of its technical capabilities, as well as the list of possible failures and methods of their elimination.

**CAUTION! It is strictly prohibited to switch on the sight in a daytime without the cover with light filter being set on and direct at bright shining objects - sun, welding and etc, as well as to observe the bright shining objects at night – direct headlamp light, fire flame and etc.**

**It is prohibited to aim the sight at metallic reflection surfaces with IR illuminator switched on.**

## **1 DESCRIPTION AND OPERATION**

### **1.1 Purpose**

1.1.1 Night sight PN 19K (hereinafter referred to as – the sight) is intended for aimed shooting from hunting weapons type «Tigr», «Tigr-1», «Tigr-9», «Tiger-9-1», «Saiga», «Saiga-5,6», «Saiga-5,6C», «Saiga-9», «Saiga-9-1», «Saiga-9-2», «Saiga-20», «Saiga-20K», «Saiga-20C», «Saiga –M3», «Saiga-308», «Saiga-308-1», «Saiga-308-2», «Saiga-410», «Vepr», «Los-7», «Los-7-1», «Bars-4», «Bars-4-1», weapon with «Picatinny» strap («Weaver rail»), weapon with «Stowner» strap, and apart from that there is an adaptor strap for self-installation of the sight on the consumer's weapon.

1.1.2 The sight is produced with the one of the three objective lenses with F27, F80 or F135. Overfocusing of the objective lens with 27 mm focus provides clear objects image at a distance of 0,5 m to infinity, with the focus of 80 mm – from 4 m to infinity, and with the focus of 135 mm – from 60 m to infinity.

1.1.3 The sight is equipped with the Image Intensifier Tube (hereinafter referred to as – IIT) Gen 2<sup>+</sup> or Gen 3, which provides recognition range of 350-450 m. The sight with IIT Gen 2<sup>+</sup> is intended for use under natural night

illumination conditions at  $(3-5) \times 10^{-3}$  lx, i.e in star light without clouds and moon light. The sight with IIT Gen3 is intended for use under illumination less than  $(3-5) \times 10^{-3}$  lk, with clouds and without the moonlight.

1.1.4 The sight is designed to operate in an open air environment within a temperature range of +40 °C to -40 °C and relative humidity up to 98% at the temperature of + 25 °C.

## 1.2 Specifications

1.2.1 The main technical features of the sight and the IIT must correspond to the table 1.

Table 1

Designation	Value
Eye relief, mm *)	40-50
Diopter adjustment range, D	from 4 to 5
Power supply voltage, V	1,2-1,5

Continuation table 1

Designation	Value
Time of continuous operation, h:	
without IR illuminator	15
with IR illuminator	3,5
Integral photocathode sensitivity, $\mu\text{A/lm}$	500-600 (Gen 2+), 1500-1800 (Gen 3)
Resolution limit, lp/mm	57-64
Conversion coefficient	25000
*) The sight is equipped with two eye shades for observation comfort.	

1.2.2 The variable technical data for the different modifications of the sight PN 19K with the regard to the bracket, objective lens and IIT are given in the table 2.

Table 2

Sight modification	IIT Gen	Recognition range, m	Magnification	Field of view	Dimensions, mm, not more	Weight, kg, not more	Note
PN 19K-1-01 PN 19K-3-01 PN 19K-5-01	2+ (3) 2+ (3) 2+ (3)	150 (200) 300 (400) 500 (600)	1 <sup>x</sup> (27F/1.17) 3 <sup>x</sup> (80F/1.4) 5 <sup>x</sup> (135F/2)	34 12,5 7,5	206×92×178 248×92×178 272×92×178	1,07 1,37 1,55	«Tigr», «Tigr-9», «Saiga-5,6C», «Saiga-20K», Saiga-20C», «Saiga-9-2», «Saiga-M3», «Saiga-308-2», «Vepr» (figure 1a)
PN 19K-1-02 PN 19K-3-02 PN 19K-5-02	2+ (3) 2+ (3) 2+ (3)	150 (200) 300 (400) 500 (600)	1 <sup>x</sup> (27F/1.17) 3 <sup>x</sup> (80F/1.4) 5 <sup>x</sup> (135F/2)	34 12,5 7,5	236×92×178 248×92×178 272×92×178	1,07 1,37 1,55	«Tigr-1», «Tigr -9-1», «Saiga», «Saiga -5,6», «Saiga-20», «Saiga-410», «Saiga-9», «Saiga-9-1», «Saiga-308»,



Continuation table 2

Sight modification	IIT Gen	Recognition range, m	Magnification	Field of view	Dimensions, mm, not more	Weight, kg, not more	Note
PN 19K-1-03	2+ (3)	150 (200)	1 <sup>x</sup> (27F/1.17)	34	255×92×118	0,97	«Saiga-308-1», «Vepr» (figure 2)  «Los-7», «Los-7-1», «Bars-4», «Bars-4-1» (figure 3)
PN 19K-3-03	2+ (3)	300 (400)	3 <sup>x</sup> (80F/1.4)	12,5	255×92×118	1,27	
PN 19K-5-03	2+ (3)	500 (600)	5 <sup>x</sup> (135F/2)	7,5	272×92×118	1,45	
PN 19K-1-04	2+ (3)	150 (200)	1 <sup>x</sup> (27F/1.17)	34	300×92×121	1,01	Weapon with «Picatinny» strap (figure 4)
PN 19K-3-04	2+ (3)	300 (400)	3 <sup>x</sup> (80F/1.4)	12,5	300×92×121	1,31	
PN 19K-5-04	2+ (3)	500 (600)	5 <sup>x</sup> (135F/2)	7,5	300×92×121	1,41	

Continuation table 2

Sight modification	IIT Gen	Recognition range, m	Magnification	Field of view	Dimensions, mm, not more	Weight, kg, not more	Note
PN 19K-1	2+ (3)	150 (200)	1 <sup>x</sup> (27F/1.17)	34	195×92×90,5	0,82	With adaptor strap (figure 5)
PN 19K-3	2+ (3)	300 (400)	3 <sup>x</sup> (80F/1.4)	12,5	248×92×90,5	1,12	
PN 19K-5	2+ (3)	500 (600)	5 <sup>x</sup> (135F/2)	7,5	272×92×93	1,26	
PN 19K-1-05	2+ (3)	150 (200)	1 <sup>x</sup> (27F/1.17)	34	218×92×127,5	0,93	Weapon with «Stownera» strap (figure 6)
PN 19K-3-05	2+ (3)	300 (400)	3 <sup>x</sup> (80F/1.4)	12,5	248×92×127,5	1,23	
PN 19K-5-05	2+ (3)	500 (600)	5 <sup>x</sup> (135F/2)	7,5	272×92×127,5	1,37	

1.2.3 The sight provides target detection, recognition and aimed shooting at direct shot distance under natural night illumination.

Recognition range of the sight depends on natural night illumination, atmosphere transparency and contrast between target and background. High ambient illumination, moonlit night, some external booster light, light

background (sand or snow) increase the recognition range. Low ambient illumination, low clouds, low atmosphere transparency and dark background (tillage, forest etc.) decrease the recognition range.

### **1.3 Nomenclature list**

1.3.1 The delivery set should correspond to the table 3

Table 3

Name	Quantity
Sight PN 19K	1
Bag	1
YK-316 battery tester	1
Spanner	1
Eyeshade	1
Napkin	1
Service manual	1

## **1.4 Design and operation**

1.4.1 The operating principle of the sight is based on intensification of a low brightness image, created by objective lens on the photocathode of IIT, into the image with the brightness, sufficient for examination through the eyepiece.

1.4.2 The sight consists of the objective lens, IIT, eyepiece, two power supplies, which are placed in the cover of the built in IR illuminator and a bracket, intended to mount the sight on the weapon.

1.4.3 The cover 1 is set on the objective lens 2 (figure 1a), which simultaneously protects the objective lens from damage and provides the sight operation in the daytime and at twilight. The focusing of the objective lens is made by turning the handwheel 3.

1.4.4 The laying of the reticle sharp image is made by turning the ring with the knurl A, located on the eyepiece 8.

1.4.5 The rubber eye shade 9 on the eyepiece provides the convenience of working with the sight and protects the eye against injury.

1.4.6 The position of the switch 11 for the sight to be switched on without reticle illumination is marked with red dot; the position "off" is marked with "OFF"; the switching on of the IR illuminator 13 is marked "\*\*\*".

The field of view of the eyepiece should shine green with black aiming marks of the reticle within 3-4 seconds after the sight was switched on. The handwheel 10 switches on the reticle illumination with red LED and adjusts its brightness.

1.4.7 The adjustment of sight in windage "L-R" (Left-Right) and in elevation "U-D" (Up-Down) is made by turning the handwheels, covered with protective caps 5, 7.

1.4.8 The connecting pipe 6 is intended for nitrogen purging.

1.4.9 The polarity of the power supply is marked on the cover 12 of the sight.

1.4.10 The brackets 1 with side fastening are used for mounting of the sights PN 19K-1-01, PN 19K-3-01, PN 19K-5-01 (figures 1b, 2, 3) on the carbine «Tigr», «Tigr -9», «Saiga-5,6C», «Saiga-20K», «Saiga-20C», «Saiga-9-2», «Saiga -M3», «Saiga-308-2», «Vepr»; and the sights PN 19K-1-02, PN 19K-3-02, PN 19K-5-02 on the carbines «Tigr-1», «Tigr-9-1», «Saiga», «Saiga-5,6», «Saiga-9», «Saiga-9-1», «Saiga-20», «Saiga-308», «Saiga-308-1», «Saiga-410», «Vepr», (figures 4, 5, 6). In order to achieve this do the following:

- fold back the handle 5 (figure 1b);

- mount the sight from the butt side and push it forward along the strap 2 until the bracket 1 sets against the strap 2;
- turn the handle 5 forward up to the stop, so that it would snap to the bracket 1;
- ensure security fastening of the sight on the weapon.

In order to adjust the fastening of the sight on the weapon it is necessary to do the following:

- remove the sight from the weapon;
- shift the latch 3, having released it from the screw head 4;
- replace the handle 5 for such a number of teeth, which provides secure fastening and eliminate the sway of the sight on the weapon;
- put the latch 3 back;
- ensure security fastening of the sight on the weapon once again.

1.4.11 The brackets 1 with upper fastening are used for mounting of the sights PN 19K-1-03, PN 19K-3-03, PN 19K-5-03 for carbines «Los-7», «Los-7-1», «Bars-4», «Bars -4-1» (figures 7, 8, 9); and the sights PN 19K-1-04, PN 19K-3-04, PN 19K-5-04 on the weapon with «Picatinny» strap («Weaver rail») (figures 10, 11, 12). In order to do this it is necessary to mount the sight on the strap

of the weapon, push it forward up to the stop and tighten the nuts 2 with spanner 3 (figure 7).

1.4.12 Adaptor strap A (figure 13) allows to adapt the sights PN 19K-1, PN 19K-3, PN 19K-5 to a specified model of the weapon. In order to do this appeal to the manufacturer.

1.14.13 Bracket 1 is used for mounting of the sights PN 19K-1-05, PN19K-3-05, PN 19K-5-05 (figures 16, 17, 18) on the weapon with strap «Stownera».

In order to do this it is necessary:

- remove the grip nut 2 from the bracket 1;
- set the sight on the prism, located at the weapon's handle;
- push the sight forward up to the stop;
- put the nut 2 and tighten it.

## **1.5 Measuring tools, tools and accessories**

1.5.1 The spanner 3 (figure 7), which is supplied together with the sight, is used to tighten the nuts 2 (figures 7, 8, 9, 10, 11, 12) while mounting the sight on the weapon.

The napkin is used to clean the external surfaces of the optical parts and the contacts of the power supply compartment.

1.5.3. The charge unit tester YK-316 (figure 19) is intended to test the charge level of the power supply type R6 GOST 28135-89 (AA).

The front panel of the YK-316 is equipped with 4 LEDs with numbers standing for voltage in volts.

To determine the charge level of the power supply, install it into the YK-316, minding the polarity. The lighted LEDs will indicate the charge level of the power supply. If all four LEDs are lighted, the voltage at the contacts of the power supply – not less than 1,4 V.

If only one (or none) of the LEDs is lighted, it is necessary to replace the power supply with a new one.

1.5.4 The bag is intended for packing and transporting of the sight.

## **2 PROPER USE**

### **2.1 Operational limitations**

2.1.1 To provide the smooth operation of the sight **it is prohibited:**  
– to switch on the sight in day light and at twilight without cover 1 (figure 1a) with light filter on;



### **Caution! The day light will break down the sight!**

– to point the sight at the bright sources of light (fire flames, searchlight, headlights and etc) even with the cover with light filter being put on.

2.1.2 Switch off the sight when the bright shining objects appear in the field of view.

2.1.3 Once the work is done switch off the sight.

2.1.4 Avoid short circuit between the power supply and metal objects.

2.1.5 It is strongly recommended to remove the power supply out of the sight and store it in the pocket to avoid unintended switching on of the sight. This measure would also extend the service life of the power supply if the ambient temperature is below zero.

## **2.2 Preparation and work procedure**

2.2.1 In order to make the sight ready for operation and to check its operability in the day time, it is necessary:

– to mount the sight onto the weapon;

**Rocking of the sight on the weapon, its sliding while shooting is not allowed.**

– place the cover 1 (figure 1a) with light filter on the objective lens 2;

- unscrew the cap 4 and load the power supply inside, with its polarities properly aligned;
- tightly close the cap 4;
- switch on the sight;
- turning the handwheel 10, try to achieve the necessary contrast of the reticle aiming point in the field of view of the eyepiece.

**Aiming is carried out by the top of the central aiming mark (angle).**

2.2.2 The weapon with sight should pass the ranging fire before using.

The ranging fire is carried out in the day time and only with the cover with light filter being installed on the objective lens, in the following way:

- set the target size 1m x 1m at a distance of 100 m;
- perform 3-4 shots, thoroughly and uniformly aiming with the top of the aiming mark (angle) at the centre of black circle of the target;
- determine the mean point of impact (MPI) by the holes on the target.

2.2.3 If the MPI does not coincide with the aiming point (center of the dark circle of target), it is necessary to adjust the sight by turning the handwheels of elevation "U-D" and windage "L-R" corrections.

For the sights PN 19K, PN 19K-1-02, PN 19K-1-03, PN 19K-1-04, PN 19K-1,

PN 19K-1-05 the turn of the handwheel with one “click” moves the MPI on 3 cm on the target at distance, equal to 100m.

**NOTE – If the ranging fire takes place at a distance of 50 m, then the value of one “click” is 1,5 cm.**

For the sights PN 19K-3-01, PN 19K-3-02, PN 19K-3-03, PN 19K-3-04, PN 19K-3, PN 19K-3-05 the turn of the handwheel with one “click” moves the MPI on 1 cm at 100 m.

**NOTE – If the ranging fire takes place at a distance of 50 m, then the value of one “click” is 0,5 cm.**

For the sights PN 19K-5-01, PN 19K-2-02, PN 19K-5-03, PN 19K-5-04, PN 19K-5, PN 19K-5-05 the turn of the handwheel with one “click” moves the MPI on 0.6 cm at 100m.

**NOTE – If the ranging fire takes place at a distance of 50 m, then the value of one “click” is 0,3 cm.**

The figure 20 for the sights PN 19K-1-01, PN 19K-1-02, PN 19K-1-03, PN 19K-1-04, PN 19K-1, PN 19K-1-05 shows, that the MPI of three holes is located 24 cm above the aiming point and 18 cm to the left. In order to move the MPI to the centre of the target, it is necessary to turn the handwheel of the elevation scale by

24/3=8 (approximate number of "clicks") downwards (D) and the handwheel of the windage scale by 18/3=6 ("clicks") to the right (R).

2.2.4 Once the changes are made perform control shooting, the precision of the weapon with sight should be as good as that of the weapon without one.

After the ranging fire don't make any other corrections to the sight settings.

2.2.5 While shooting at the distance of more than 100 m, perform the ranging fire as well but choose another aiming point that corresponds to the target distance.

# FIGURES

a) General view of the sight

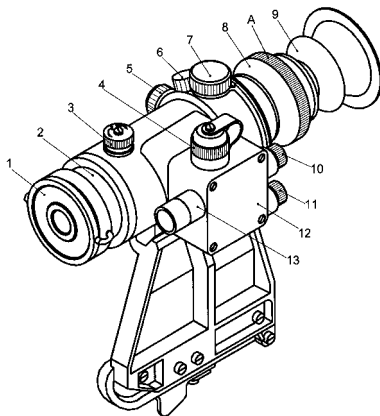

1 – cover; 2 – objective lens; 3 – hadwheel; 4 – cap; 5 – cap;  
6 – connecting pipe; 7 – cap; 8 – eyepiece; 9 – eyeshade; 10 – handwheel;  
11 – switch; 12 – cover; 13 – IR illuminator

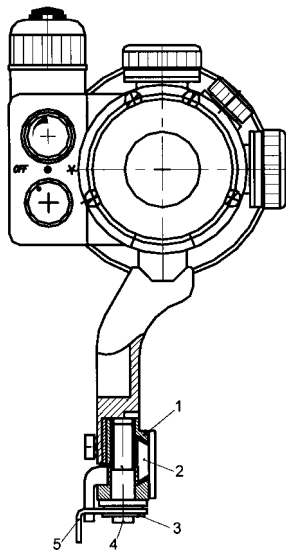

b) Sight mounting on the weapon

1 – bracket; 2 – mount seat of weapon; 3 – latch;  
4 – screw; 5 – handle

Figure 1 – **General view of the sight PN 19K-1-01**

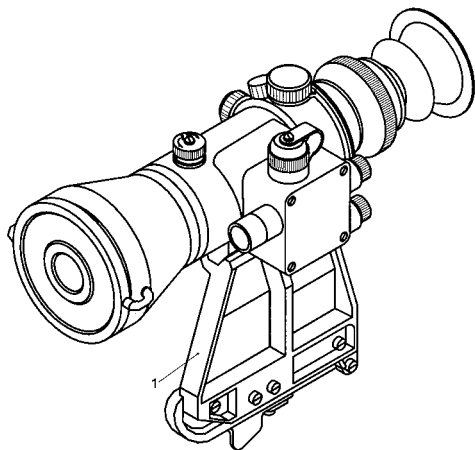

1 – bracket

Figure 2 – **General view of the sight PN 19K-3-01**



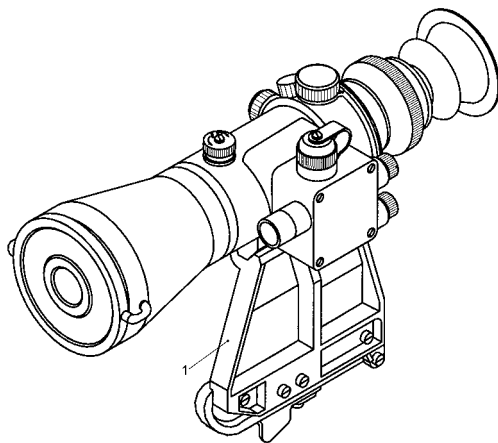

1 – bracket

Figure 3 – **General view of the sight PN 19K-5-01**

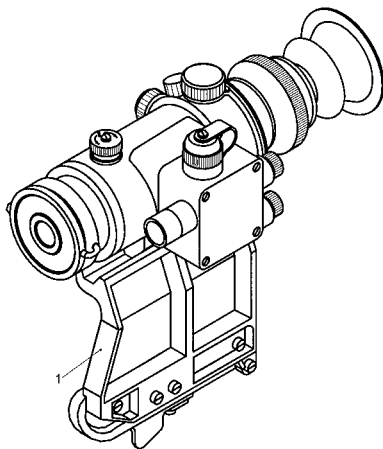

1 – bracket

Figure 4 – **General view of the sight PN 19K-1-02**

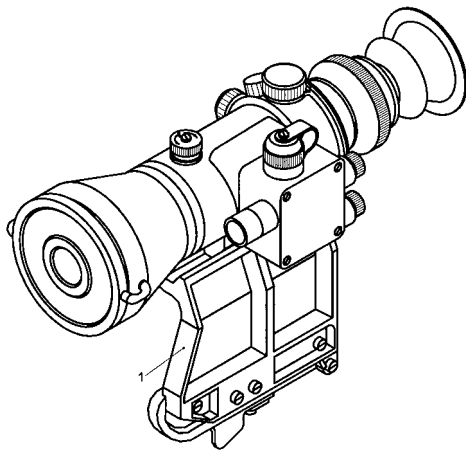

1 – bracket

Figure 5 – **General view of the sight PN 19K-3-02**

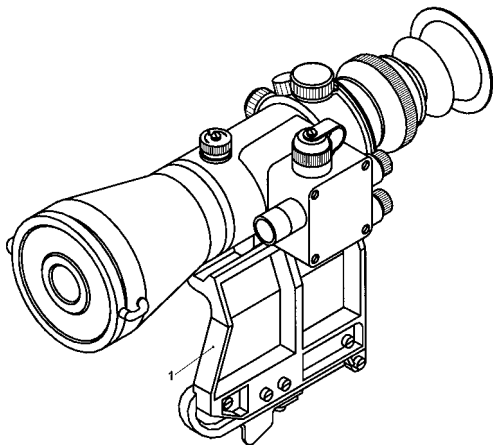

1 – bracket

Figure 6 – **General view of the sight PN 19K-5-02**

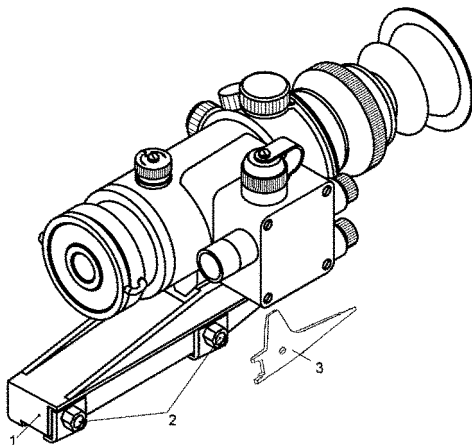

1 – bracket; 2 – nuts; 3 – spanner

Figure 7 – **General view of the sight PN 19K-1-03**

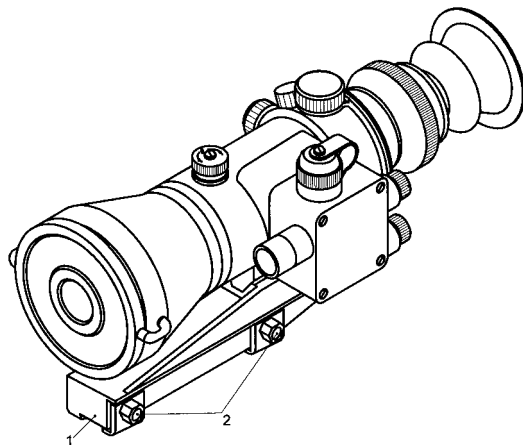

1 – bracket; 2 – nuts

Figure 8 – **General view of the sight PN 19K-3-03**

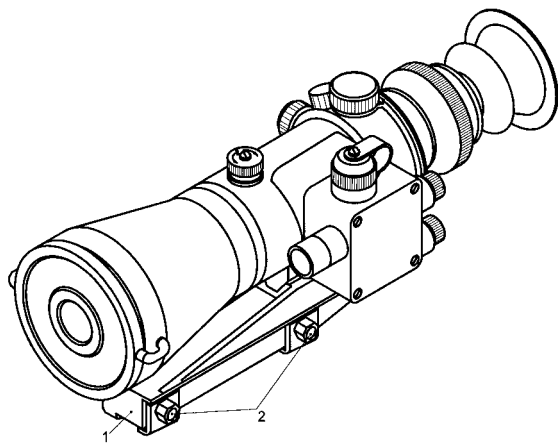

1 – bracket; 2 – nuts

Figure 9 – **General view of the sight PN 19K-5-03**

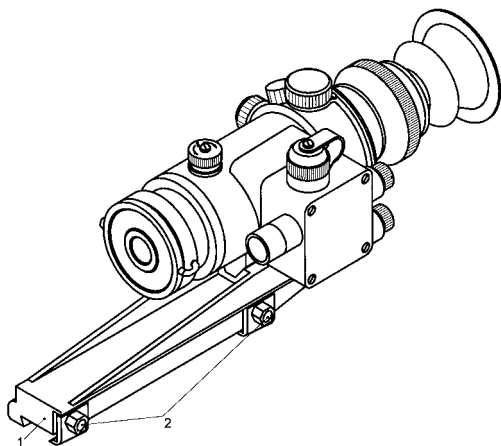

1 – bracket; 2 – nuts

Figure 10 – **General view of the sight PN 19K-1-04**



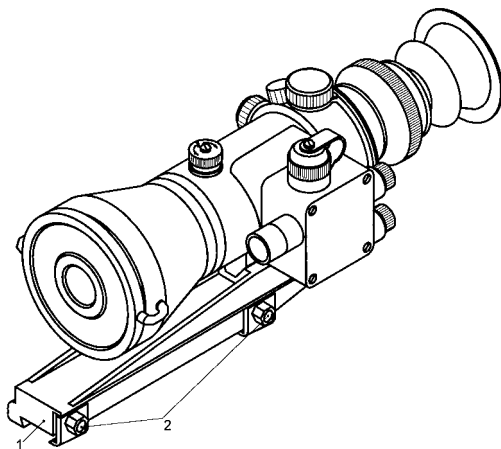

1 – bracket; 2 – nuts

Figure 11 – **General view of the sight PN 19K-3-04**

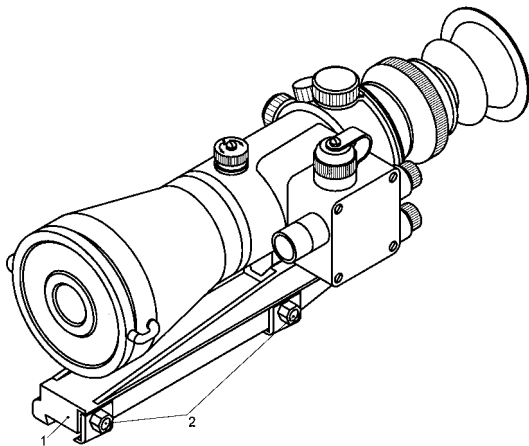

1 – bracket; 2 – nuts

Figure 12 – **General view of the sight PN 19K-5-04**



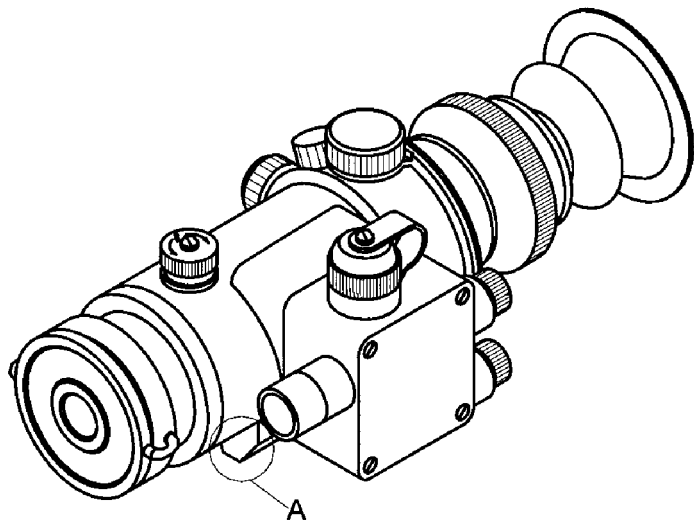

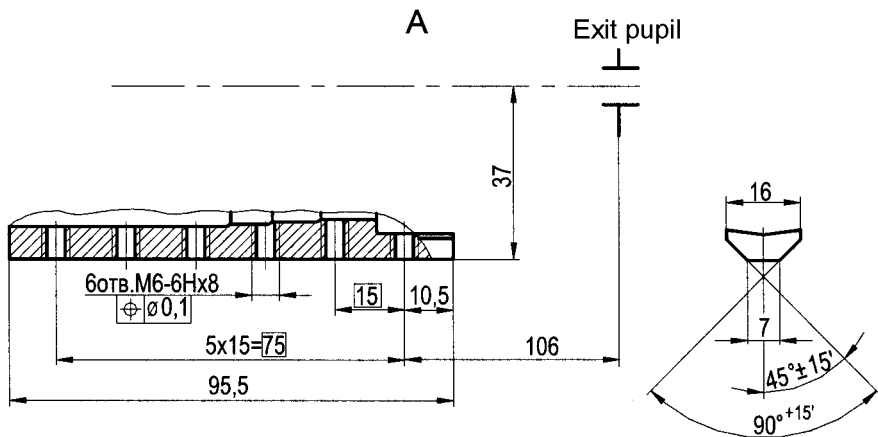

Figure 13 – General view of the sight PN 19K-1

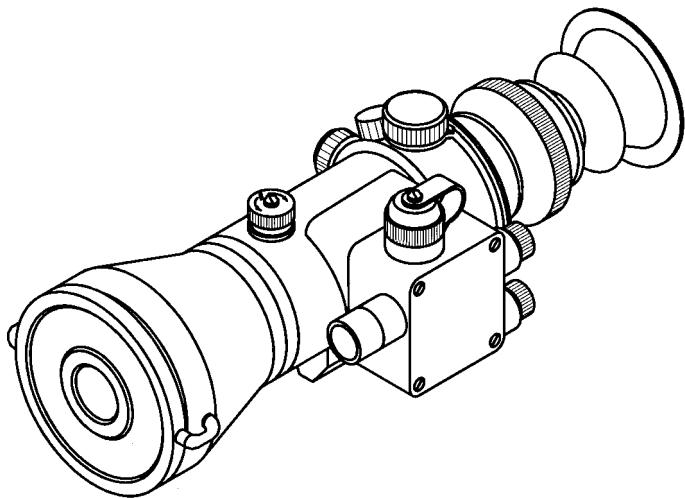

Figure 14 – **General view of the sight PN 19K-3**

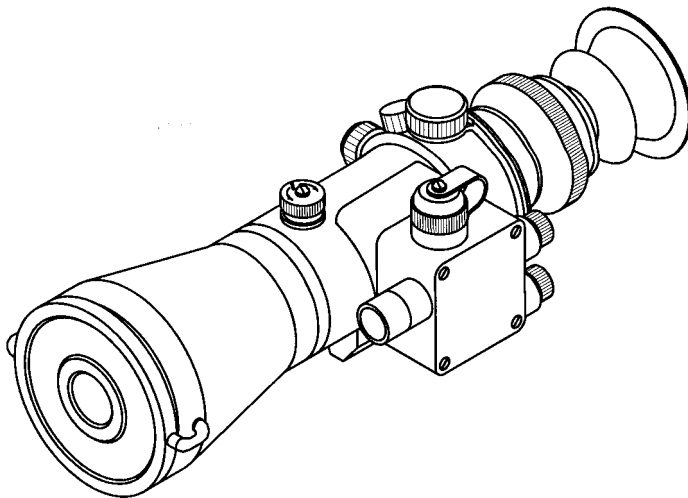
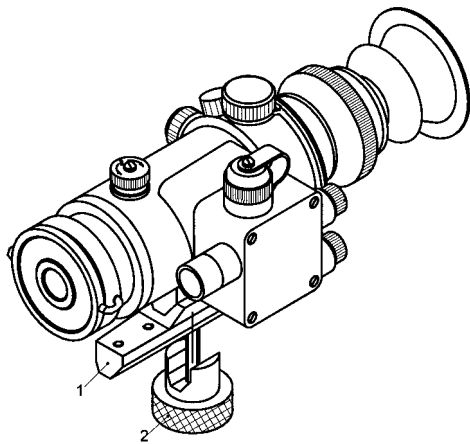

Figure 15 – **General view of the sight PN 19K-5**



1 – bracket; 2 – nuts

Figure 16 – **General view of the sight PN 19K-1-05**



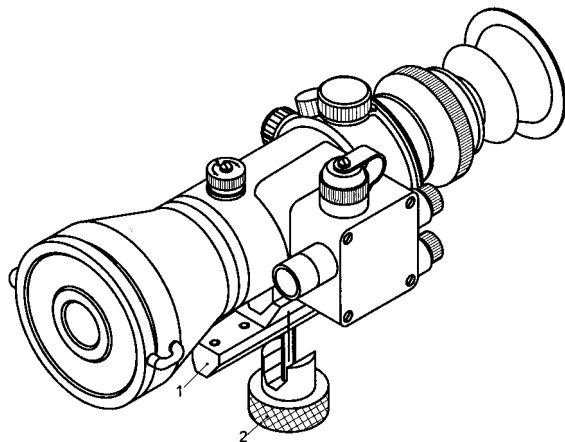

1 – bracket; 2 – nuts

Figure 17 – **General view of the sight PN 19K-3-05**

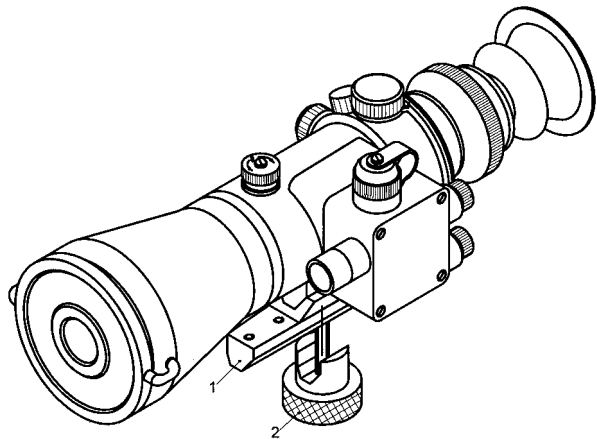

1 – bracket; 2 – nuts

Figure 18 – **General view of the sight PN 19K-5-05**

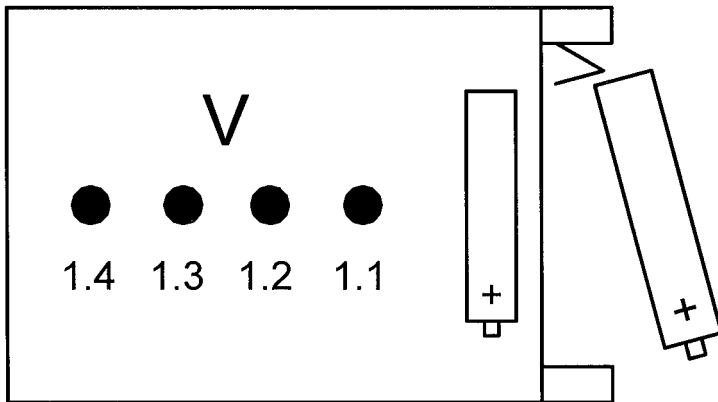

Figure 19 – **Scheme of the power supply installing in YK-316**

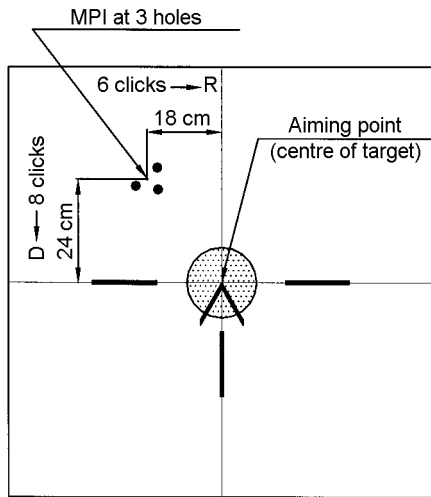

Figure 20 – Ranging target

## **3 MAINTENANCE**

### **3.1 General instructions**

3.1.1 Keep the sight clean, protect it from dust and dirt. External surfaces of the optical parts must be always clean.

To provide the smooth operation of the sight **it is prohibited:**

- to disassemble the sight;
- to switch on the sight in day light and at twilight without the cover with light filter on;
- to use other types of the power supply;
- to store the sight with the power supply in.

The maintenance of the sight should include the following procedures:

- wipe the sight against dust, dirt and moisture;
- check the contacts of the power supply;
- remove oil spots from the glass surface with clean napkin, in the case of sever dirtying use alcohol.

### **3.2 Safety measures**

3.2.1 To avoid injury during operation, insure the sight is securely attached to the weapon.

3.2.2 Avoid an excessive pressure to eyeshade when viewing. The eyeshade can be pressed only until clear boundary of the field of view appears in order to avoid eye injuries during fire.

3.2.3 To avoid pollution of the environment, it is recommended to dispose of used batteries appropriately.

### **4 POSSIBLE FAILURES AND METHODS OF THEIR ELIMINATION**

4.1 In the case of a trouble in the sight operation it is necessary to check the following:

- the mounting of the sight on the weapon;
- whether the cover with light filter is placed on the objective lens;
- the objective lens and the eyepiece are free of dust, dirt, oil, hoar and water;

- whether the power supply is not discharged;
- whether the sight is switched on;
- the power supply is loaded with its polarities properly aligned.

Special attention must be paid to the cleanness of the power supply contacts.

4.2 The possible malfunctions and damages are listed in the table 4 as well as instructions for their elimination.

Table 4 – The list of possible malfunctions

Malfunction	Possible cause	Methods of elimination
Image intensifier screen does not shine or shines weakly	Power supply is discharged  Power supply is improperly installed  IIT is failed	Replace power supply with a new one  Reload power supply with its polarities properly aligned  Send the sight to repair shop

Continuation table 4

Malfunction	Possible cause	Methods of elimination
Image brightness rises to maximum and falls down fast or fluctuates disturbing the sight operation	Light overload	Put the cover with light filter on the objective lens
Poor or blurred image quality	External surfaces of eyepiece and objective lens are damp or dirty	Wipe the external surfaces of objective and eyepiece with napkin
Poor or blurred image quality. There are flashes and blinking in the sight's field of view	Inner surfaces of objective lens, eyepiece and photocathode of IIT are damp	Send the sight to repair shop to dry it out and eliminate the depressurization



Continuation table 4

Malfunction	Possible cause	Methods of elimination
Dark spots have appeared in the field of view of the sight that obstructs the sight operation	IIT is damaged by exposure to bright light source. Flaking of the photocathode or of the IIT screen	Send the sight to repair shop
Reticle shines weakly or it does not shine at all	1 Reticle illumination device is failed 2 Power supply is discharged	1 Send the sight to repair shop 2 Replace the power supply

## 5 STORAGE

5.1 The sight should be stored in a heated room within a temperature range of +5 °C to +35 °C and relative humidity up to 85 %.

5.2 It is recommended to store the sight in the bag without power supply inside.

## 6 ACCEPTANCE CERTIFICATE

Night sight PN 19K \_\_\_\_\_, serial No. \_\_\_\_\_, is manufactured in accordance with mandatory state requirements, technical documentation and is fit for operation.

Date of issue \_\_\_\_\_

Signatures \_\_\_\_\_  
(stamp)

Federal State Unitary Enterprise  
"Production Amalgamation  
"Novosibirsk Instrument-Making Plant",  
179/2 D.Kovalchuk Str.,  
Novosibirsk, 630049  
Russian Federation