



TAL REFRACTING TELESCOPES

TAL-100RS

TAL-125R

INSTRUCTION MANUAL

NPZ Optics State Corp.
(Novosibirsk Instrument-making plant)
D. Kovalchuk 179/2 Novosibirsk,
630049 RUSSIAN FEDERATION
Fax +7 3832 261594
prinsib@sol.ru;
www.npzoptics.com

TABLE OF CONTENTS

	Page
General instructions	4
Technical specifications	5
Inventory list	6
Construction of the telescope	8
Preparing telescope for observations	11
Assembling the telescope	11
Balancing the telescope	12
Aligning the finder scope	13
Power supply and hand controller	14
Polar alignment	15
Calibrating the setting circles	17
Observations	18
Visual observations	18
Astrophotography	19
Maintenance	20
Collimation (alignment) of the optics	21
Storage	22
Acceptance certificate	23
Appendix A: Brightest stars visible in the Northern Hemisphere	24

Due to continuous product improvements, specifications are subject to change without notice.

GENERAL INSTRUCTIONS

Warning!

Never observe the Sun directly through your telescope or its finder scope - permanent eye damage could result.

Do not let children hold observations through telescope without adult's control.

- ❑ The telescope is designed for visual observations of celestial objects and for astronomical photography. It requires careful treatment and some knowledge of astronomy. Only in this case the use of telescope will bring satisfaction to its owner.
- ❑ The telescope may be used at an ambient temperature ranging from 30° to -30°C.
- ❑ When buying the telescope inspect the package to make sure that the original packaging is in good condition, and seals are not broken or missing. Having opened the package, check the presence of all components described in inventory list.
- ❑ Read instruction manual first before using the telescope.

TECHNICAL SPECIFICATIONS

Specification	TAL-100RS	TAL-125R
Aperture, mm	100	125
Focal length, mm	1000	1125
Focal ratio	1:10	1:9
Telescope magnification, x	40; 160;	45; 180;
Resolving power	1,3"	1"
Limiting visual magnitude	11,2 ^m	12,0 ^m
Finderscope magnification, x	6	6
Finderscope aperture, mm	30	30
Focuser	1,25";2"	1,25";2"
Right ascension turning angle	360° (24 ч)	360° (24 ч)
Declination turning angle	±90°	±90°
Latitude adjustment range	0...70°	0...70°
Input voltage V AC	220	220
Frequency, Hz	50	50
Power, Watts	5	5
Output voltage, V	12 DC	12 DC
Dimensions, mm:		
OTA* length	1080	1250
Telescope height	1450	1500
OTA weight, kg	4,3	6,0
Telescope weight, kg	23	25

*Optical Tube Assembly

INVENTORY LIST

Component	TAL-100RS	TAL-125R
Telescope	+	+
Finderscope:		
6x30	+	+
Polar axis finderscope 6x23	+	+
Equatorial mount		
MT-3S (MT-3S-2D):		
with counterweight 2.2 kg	+	-
with counterweight 3.7 kg	-	+
Tripod:		
wooden	-	-
metal	+	+
Power supply	+	+
Hand controller	+	+
Power cord (10 m)		
Spare parts and accessories:		
Plössl eyepiece $f=6.3\text{mm}$	+	+
Plössl eyepiece $f=25\text{mm}$	+	+
Reticle	+	+
T-adapter M42x0.75	+	+
Instruction manual	+	+
Optional accessories:		
Pier:		
C75 (1000mm)	-	-
C110 (800mm)	-	-
Plössl eyepieces (1.25"):		
$f=7.5\text{mm}$	-	-
$f=12.5\text{mm}$	-	-
$f=17\text{mm}$	-	-
$f=20\text{mm}$	-	-
$f=32\text{mm}$	-	-
$f=40\text{mm}$	-	-
Super wide angle eyepieces (1.25"):		
$f=10\text{mm}$ (60°)	-	-
$f=15\text{mm}$ (65°)	-	-
$f=20\text{mm}$ (65°)	-	-

Component	TAL-100RS	TAL-125R
Ultra wide angle eyepieces (80°):		
f'=15mm (1.25")	-	-
f'=20mm (2")	-	-
f'=24mm (2")	-	-
f'=25mm (2")	-	-
Direct observation lens:		
PP-45° (1.25")	-	-
PP-45° (2")	-	-
2x Barlow lens	-	-
3x Barlow lens	-	-
Guide eyepieces 12.5mm (1.25")	-	-
Off-axis guider (2")	-	-
Color filters M28.5x0.6:		
black	-	-
neutral	-	-
yellow	-	-
blue	-	-
red	-	-
green	-	-
Color filters M48x0.75:		
black	-	-
neutral	-	-
yellow	-	-
blue	-	-
red	-	-
green	-	-
Power cord extension cable with car adapter (10m)	-	-

CONSTRUCTION OF THE TELESCOPE

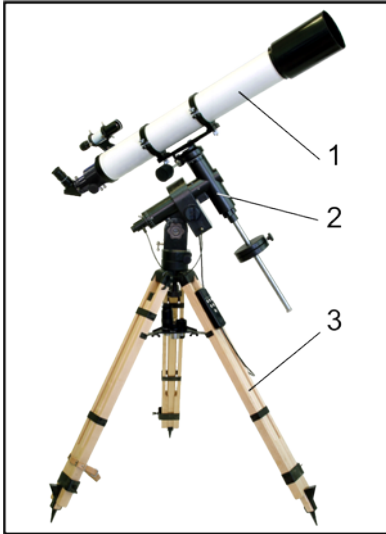

- ❑ The telescope consists of three main parts: optical tube assembly (OTA) (1), German equatorial mount (2), a pier or tripod (3).

The optical tube is a basic component of the telescope. It includes all main optical units such as a primary mirror, a corrector and an eyepiece unit with focusing mechanism.

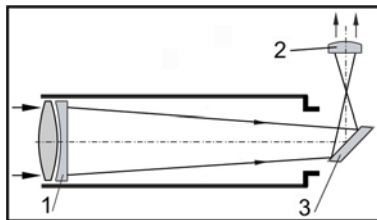

- ❑ A Refractor Telescope: parallel beam of rays enters the tube of the telescope and is projected at the focal plane of the eyepiece (2) with the help of achromatic eyepiece (1).
- ❑ For comfort observations eyepiece unit is inclined on 90° relatively to the optical axis of the telescope with help of flat diagonal mirror (3).
- ❑ A standard set includes two eyepieces and a Barlow lens, which allow observing celestial objects with various rate of magnification.
- ❑ The OTA supplied with a finder-scope, makes searching for celestial objects easier.
- ❑ Mirrors' effective areas are covered with high reflection aluminum coatings with protective level.

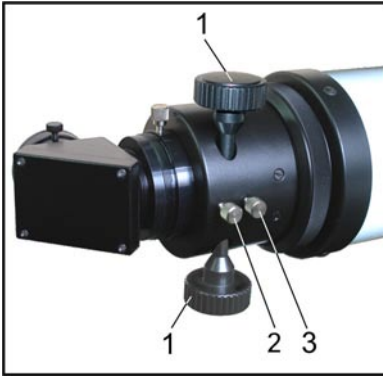

- ❑ All lenses surfaces are covered with antireflecting coating.
- ❑ The eyepiece unit includes a focuser with an eyepiece tube.
- ❑ Focuser of frictional type consists of an axis with handwheels (1) for shifting an eyepiece tube.
- ❑ Smoothness of an eyepiece motion is regulated with a screw (2).
- ❑ Screw (3) fixes an eyepiece tube in the adjusted position.

The equatorial mount is designed for pointing the telescope at the celestial objects and tracking their movement.

MT-3S mount consists of two perpendicular axes: the polar axis and the axis of declination. There is a mounting plate with OTA rings on the top point of the declination axis, and a counterweight shaft with counterweights on the other side.

The mount head has a clock drive embedded, which enables tracking of celestial objects with user defined speed.

The speed is set by a hand controller and has three tracking rates: solar, lunar and stellar, as well as two additional correction speeds - acceleration and deceleration at 50%. Hand controller has a night light lamp.

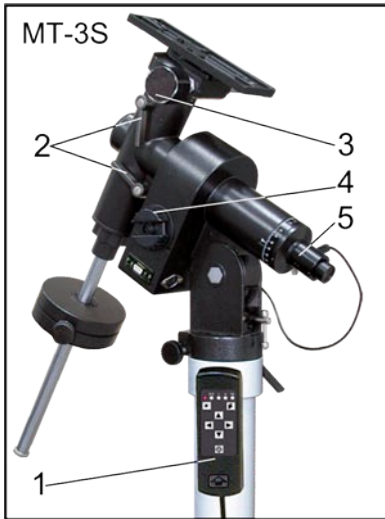

- ❑ For the first sight-in on the object, loosen the telescope's Dec. and R.A. locks (1) and move the telescope to center an object in the field of view.
- ❑ The fine alignment is done by manual Dec. slow-motion controls (2) on Dec. axis, and R.A. slow-motion controls (3) embedded into the clock drive.
- ❑ The polar axis has embedded polar axis finderscope (optional) (4) and is fixed in a tripod (pier) mounting head with a latitude dial.

The pier serves for holding an equatorial mount with an OTA. It consists of the tube and three attachable legs.

The tripod can be better used on a rugged terrain.

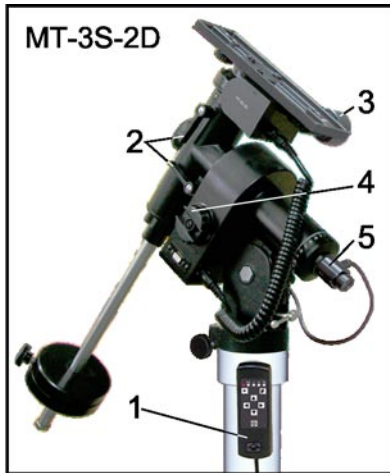

PREPARING TELESCOPE FOR OBSERVATIONS

ASSEMBLING THE TELESCOPE

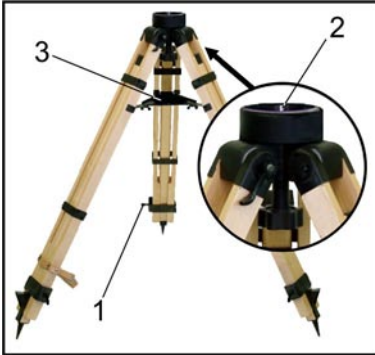

- ❑ Take a tripod out of the package. Place the pier on a firm plain surface. Regulate the needed height with help of pullout legs, which are fixed by knobs (1). The pin (2) should be oriented to the North. The tripod is equipped with an accessory shelf (3) for comfort observation.

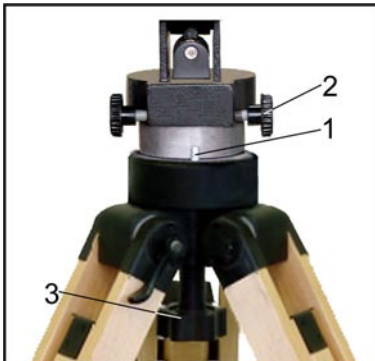

- ❑ Take the equatorial mount out of the package and place it on the top of the tripod.
- ❑ Check the pin (1) to be between two azimuth adjustment knobs (2).
- ❑ Fix the mount on the tripod tightly with help of knob (3). Make sure there is no wobbling of the mount on the tripod.

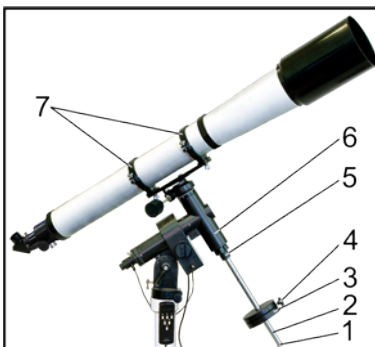

- ❑ Thread the counterweight shaft (2) into the base of the Declination axis (6) of the equatorial mount and fix it with the lock-nut (5). Unscrew the safety washer/knob (1) and slide the counterweight (3) to the midpoint on the counterweight shaft and secure it in place with the lock knob (4). Screw back in the safety washer/knob (1).
- ❑ Fix the tube rings (7) on the mounting and lay out the OTA in the rings.

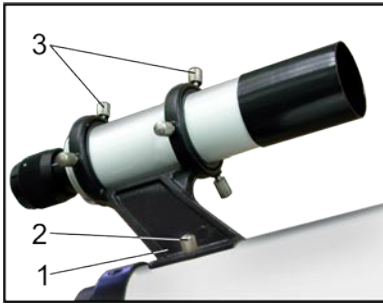

- ❑ Place the finderscope bracket (1) in the wedge slides. Fix the finderscope with six thumbscrews (2).

BALANCING THE TELESCOPE

To provide a smooth motion of the telescope and reliable operation of equatorial mount drives, the balancing of the telescopes is required.

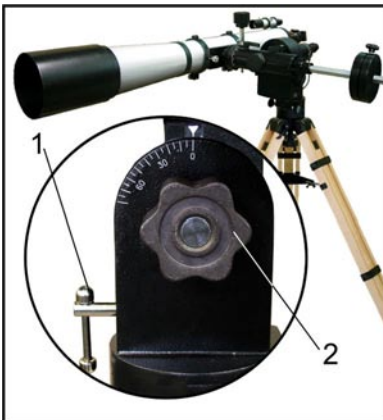

- ❑ Place the polar axis in the horizontal position (0° on the latitude dial), using the width adjustment mechanism (1) with the loosen slow-motion control (2).
- ❑ Enable unrestricted motion of the polar axis, turning the handle (1) counter clock-wise.
- ❑ Slide the counterweights along the counterweight shaft until they counterbalance the OTA.
- ❑ Fix the polar axis.
- ❑ Now enable unrestricted motion of the Dec. axis, turning the handle (2) counter clock-wise.

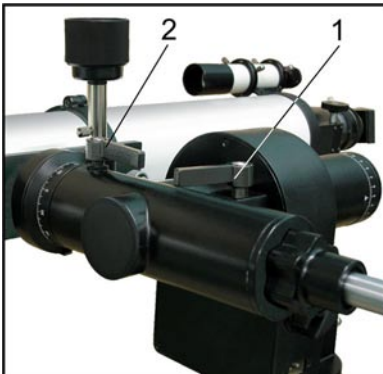

- ❑ Fix the tube and the Dec.axis.
- ❑ Repeat balancing each time when placing additional accessories on the telescopic tube, such as photo and video cameras, eyepieces, guides and other devices, which enlarge the weight of the OTA. Keep in mind that if the telescope is not balanced properly, the clock drive periodic error will increase.

ALIGNING THE FINDER SCOPE

High magnification of the main telescope makes it difficult to find a required celestial object in the sky because of the small field of view. This is why the telescope is equipped with a low-power finder scope with a wide field of view. The finder scope makes it easier to locate the object you want and then to observe it in the field of view of the telescope. However, for the proper use of the finder scope, it must be aligned with the main telescope, so that both the finder scope and the telescope point at the same position in the sky.

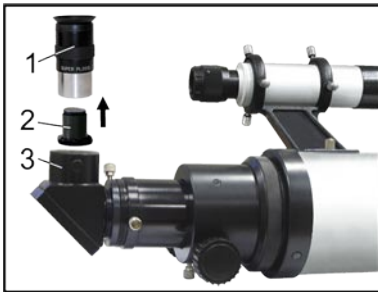

- ❑ Place the crosshair (2) into the eyepiece $f'=25\text{mm}$ (1) and then insert the eyepiece in the focuser tube (3).
- ❑ Point the telescope at the distant object (at least 400 meters/yards away), and then center it in the telescopic field of view using the reticle. Fix telescope in this position with the R.A. and Dec. locks.

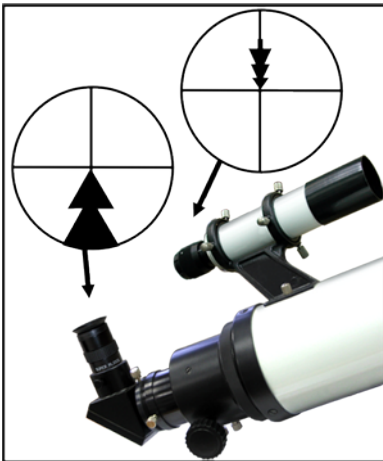

- ❑ Now, looking through the finder scope and using the six alignment thumbscrews, center the object on the intersection of the crosshairs of the finder scope. In future, check the coalignment of the telescope and the finder scope prior to observations.

POWER SUPPLY AND HAND CONTROLLER

Warning!

Always connect power supply to the mount using the power cord with power supply disconnected from the power outlet.

Use only original manufacturer's power supply fuse or analogue (consult your dealer).

Always disconnect all the power, if replacing the power supply fuse.



- ❑ Place the switch of the power supply in the "0" position.
- ❑ Connect the power supply 12V output with the mount socket using the power cord.
- ❑ Plug in the power supply into the 220/110 V AC power outlet.
- ❑ Place the switch of the power supply in the "1" position. The LED light on the power supply should turn on.
- ❑ Connect hand controller to the mount with the special cutoff point (1).

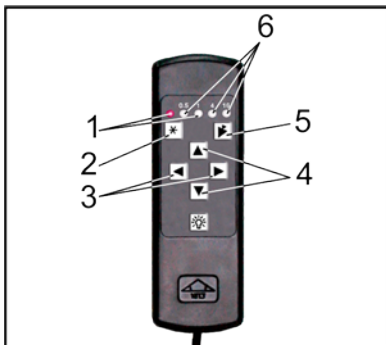

- ❑ Press one of the speed buttons (1) to start the clock drive. The LED light on the hand controller should turn on (2). Push the same button again to stop the clock drive.
- ❑ Press one of the two speed correction buttons (3) while clock drive is working, if necessary. The LED light on the hand controller should blink (2) while button is pressed down.

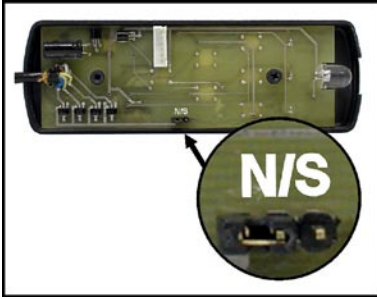

- ❑ If the telescope is used in the Southern hemisphere, the direction of the clock drive rotation must be changed.
- ❑ This is done with help of switcher inside the hand controller.
- ❑ Open the hand controller cover and place the inside switch with «N/S» (North/South) markings in the required position.

POLAR ALIGNMENT

Due to the Earth's rotation, celestial objects move in the telescope field of view (the higher telescope magnification - the faster those movements appear).

Polar alignment of the telescope allows more comfortable observations, because you can follow objects by moving the telescope about one axis, the polar axis (or Right Ascension (R.A.) axis), which is in parallel with the Earth's axis.

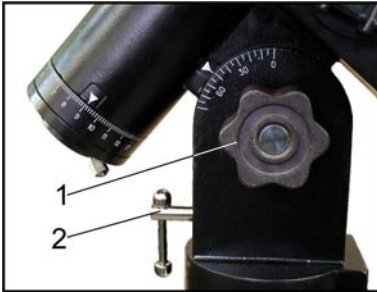

- ❑ Release the latitude lock (1). Using latitude adjustment knob (2), move R.A. axis up or down in order to set the latitude of your location (see latitude dial).
- ❑ Re-tighten the latitude lock (1).

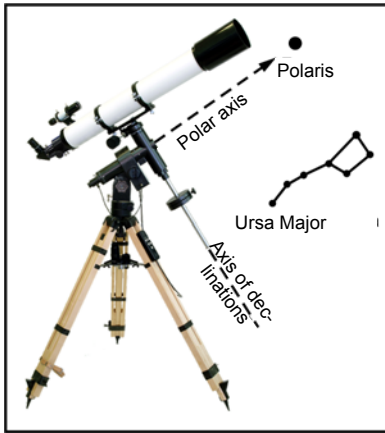

- ❑ For visual observations point the R.A. (polar) axis of the telescope towards Polaris (α UMi). See the picture.
- ❑ With this level of pointing accuracy, very little use of the Dec. slow-motion control is necessary for celestial objects tracking. Less correction is required, when polar alignment is done more precisely.

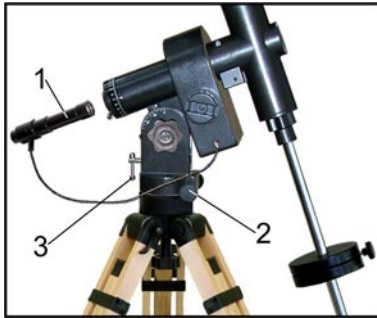

- ❑ More precise polar alignment is required for astrophotography.
- ❑ MT-3S mount equipped with a polar axis finder scope (1), for precise polar alignment, with a reticle illumination. The reticle also has major stars of the Ursa Minor constellation, including Polaris, depicted for the Northern hemisphere, and stars of the Octans constellation for the southern hemisphere.
- ❑ Match stars depicted on the reticle with the celestial objects in the sky, using azimuth (2) and latitude (3) adjustment knobs and rotating the polar axis finder scope around its axis.

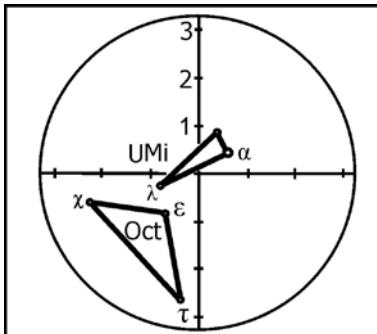

CALIBRATING THE SETTING CIRCLES

R.A. and Dec. axes have setting circles, which enable observer to locate an object in the sky by its celestial coordinates – right ascension (R.A.) and Declination (Dec.).

Calibration of setting circles is done after polar alignment of the telescope.



- ❑ Level the Dec. axis (put it in the horizontal position) and by rotating R.A. setting circle put it in a «0» (zero) position (see picture).



- ❑ For the Dec. setting circle calibration find a bright star from the star atlas, and bring selected object to the center of the telescopic field of view. Rotating Dec. setting circle (1), set the Declination of the star observed. Correct Dec. setting circle calibration by selecting next star.

OBSERVATIONS

When using higher magnification not only the visible image size appears larger in the telescope, but also blurring and distortion of the image, star twinkle, caused by atmosphere become more significant.

Please note that some nights could have bad observation conditions because of the atmospheric turbulence. Even observing fine Moon surface details can be difficult.

Avoid observations through a window, because of the window glass aberrations, and temperature differences between inside and outside air, which will cause images to look blurred and distorted.

Put a soft cover on the telescope and its power supply after observations, or to protect it from rain/snow.

VISUAL OBSERVATIONS

- ❑ Point the telescope at any chosen object, and do some coarse adjustments to put it in the finder scope field of view. Then center the object using slow motion controls – first in the finderscope and then in the main telescope field of view, when observing through the eyepiece.

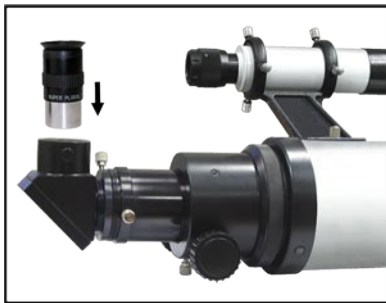

- ❑ Use focus knobs to focus, when changing eyepieces. Provided eyepieces give several magnification options for an observer.

TAL-100RS	
Plössl $f=25$ mm	Plössl $f=6.3$ mm
40 ^x	160 ^x

TAL-125R	
Plössl $f=25$ mm	Plössl $f=6.3$ mm
45 ^x	180 ^x

ASTROPHOTOGRAPHY

Astrophotography is executed with compact reflex camera with objective thread M42x1 (M42x0.75 thread camera adapter is also supplied with the telescope).

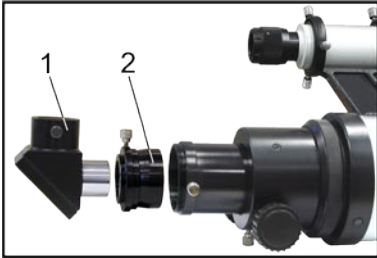

- To mount the camera on the telescope, take the mirror (1) and a camera adapter (2) away and unscrew the camera objective.
- Screw the camera adapter into the focuser drawtube.
- Attach the T-ring (T-adapter) to the camera and thread it onto the camera adapter.
- Precise guiding can be done with an off-axis guider or a guide-telescope (sold separately).
- Use slow motion controls and buttons of hand controller to avoid shifting of the star from the reticle.
- To minimize such adjustments and for better photography quality more precise polar alignment is required.

MAINTENANCE

In order to keep telescope in good operating condition one should provide good care and maintenance for the instrument. Please note that lens or mirror surfaces should be cleaned as infrequently as possible, only when absolutely necessary.

Optics self-cleaning only permitted after expiration of manufacturer limited warranty!

- ❑ Keep telescope clean and protect it from any physical damage.
- ❑ Use a clean, soft cloth to remove dust from all metallic surfaces. Then wipe them with a cloth wetted in acid-free vaseline and dry with a napkin.
- ❑ Wipe the objective and eyepiece lenses by dry linen napkin. Grease spots remove by cotton cloth, wetted with the pure spirit (alcohol).
- ❑ Use the cotton cloth, wetted with the pure spirit (alcohol), without pressure to clean the secondary mirror surface, having removed dust from their surfaces by soft brush first to avoid small scratches.
- ❑ Keep the dust cover on the front of the telescope and the end cap on the focuser tube when not in use.

COLLIMATION (ALIGNMENT) OF THE OPTICS

In case of accidental mirrors misalignment or after cleaning optical parts, telescope collimation might be necessary.



- ❑ Set the Plössl $f'=6.3$ mm into the OTA.
- ❑ Point the telescope to any star of 4^m - 5^m magnitude.
- ❑ Take away the cup (1) and secure star diffraction image with help of four knobs. Star diffraction image should have round kernel and not more than 2 round rings. Breaks and kernel form change are not allowed.
Effectiveness reduction within first diffraction ring is allowed only.
- ❑ If the weather does not allow getting the clear diffraction image of the star, make the adjustment orienting on slightly out-of-focus image, but the energy should be spread equally around the kernel.
Such operations require certain skills and qualifications.

STORAGE

- ❑ The telescope must be kept in a clean, dry (humidity must not exceed 80%), dust-free place with an ambient temperature between +5° and +40°C.
- ❑ Avoid collision and shaking of the telescope.
- ❑ It is prohibited to store acids, alkalis, and any chemically active substances, which may produce evolved gas or vapor harmful for the optics, at the same place with the telescope.

ACCEPTANCE CERTIFICATE

Telescope _____ , serial # _____

Equatorial mount, serial # _____

Passed the product approval and found serviceable.

Manufacturing date _____

Signatures _____

Appendix A

Brightest stars visible in the Northern Hemisphere

Star		Constellation	R. A. 2000.0	Declination 2000.0	Visible magnitude
Alpheratz	α And	Andromeda	0 ^h 08 ^m	+29°05'	2.07 ^m
Mirach	β And	Andromeda	1 ^h 09 ^m	+35°37'	2.07 ^m
Polaris	α UMi	Ursa minor	2 ^h 31 ^m	+89°15'	1.97 ^m
Mirfak	α Per	Perseus	3 ^h 24 ^m	+49°51'	1.79 ^m
Aldebaran	α Tau	Taurus	4 ^h 35 ^m	+16°30'	0.87 ^m
Rigel	β Ori	Orion	5 ^h 14 ^m	-8°12'	0.18 ^m
Capella	α Aur	Auriga	5 ^h 16 ^m	+45°59'	0.08 ^m
Betelgeuse	α Ori	Orion	5 ^h 55 ^m	+7°24'	0.45 ^m
Sirius	α CMa	Canis Major	6 ^h 45 ^m	-16°42'	-1.44 ^m
Castor	α Gem	Gemini	7 ^h 34 ^m	+31°53'	1.58 ^m
Procyon	α CMi	Canis Major	7 ^h 39 ^m	+5°13'	0.40 ^m
Pollux	β Gem	Gemini	7 ^h 45 ^m	+28°01'	1.16 ^m
Regulus	α Leo	Leo	10 ^h 08 ^m	+11°58'	1.36 ^m
Merak	β UMa	Ursa Major	11 ^h 01 ^m	+56°22'	2.34 ^m
Dubhe	α UMa	Ursa Major	11 ^h 03 ^m	+61°45'	1.81 ^m
Phecda	γ UMa	Ursa Major	11 ^h 53 ^m	+53°41'	2.41 ^m
Alioth	ϵ UMa	Ursa Major	12 ^h 54 ^m	+55°57'	1.76 ^m
Mizar	ζ UMa	Ursa Major	13 ^h 23 ^m	+54°55'	2.23 ^m
Spica	α Vir	Virgo	13 ^h 25 ^m	-11°09'	0.98 ^m
Alcaid	η UMa	Ursa Major	13 ^h 47 ^m	+49°18'	1.85 ^m
Arcturus	α Boo	Bootes	14 ^h 15 ^m	+19°10'	-0.05 ^m
Vega	α Lyr	Lyra	18 ^h 36 ^m	+38°47'	0.03 ^m
Altair	α Aql	Aquila	19 ^h 50 ^m	+8°52'	0.76 ^m
Deneb	α Cyg	Cygnus	20 ^h 41 ^m	+45°16'	1.25 ^m